

Excellence Compact Black



Placement and connections

This leaflet provides information about space- and connection requirements to ensure safe and successful installation, and operation of your coffee machine.

The installation technician takes care of equipment installation from the wall socket(s) and the water connection point. This excludes drilling of holes in the counter or table-top to guide power cords, hoses or chutes trough.

Please consult your local JDE Professional helpdesk for more information and explanation.

Please see the product brochure for more detailed information regarding range of available drinks, specifications, options and accessories.



Placement and connections

**THE BASIS FOR
GREAT COFFEE**

Excellence Compact Black



Placement and connections

Please observe the guidelines to maximize safety and performance

units of measurement = mm

Please consult your local JDE Professional helpdesk for more information and explanation.
Please see the product brochure for more detailed information regarding range of available drinks, specifications, options and accessories.



⚡ POWER SUPPLY
Power consumption (rated): 2100 W (230V)
Wall outlet with earth connection
(in compliance with your local regulations),
230VAC/50Hz, 16A
Distance from machine : <1 mtr.

An additional power outlet is required for an optional cold water unit or accessories.

💧 WATER CONNECTION
(in compliance with your local regulations)
Copper piping (or similar material - approved for drinking water supply)
Non-return valve (mandatory in many countries – check your local regulations)
Water tap : 3/4" or 3/8"
Distance from machine : <1 m
Water hose length : 1000 mm
Dynamic pressure : min. 1 bar at 10 L/min
Static pressure : max. 8 bar non-shock

DIMENSIONS
H 562 mm x W 390 mm x D 410 mm
(add 100 at both sides of the machine for service and maintenance purpose)
Empty weight : ca. 22 kg
Operational weight : ca. 24 kg
(water tank version 27 kg)

- 🗺 OTHER**
- ⓘ The electrical socket should not be located within a distance of 30 cm/12" or below the water connection point.
 - ⓘ The wall socket and water stop valve should be located in the same room as the equipment and easily accessible.
 - ⓘ Do not use power extension cords.
 - ⓘ The equipment is only suitable for indoor use. (temperature: 1 ~ 32 °C, humidity: <80% RH)
 - ⓘ Please check the Cafitesse ingredient packs for storage requirements and handling.

Excellence Compact Black



Options and water treatment

Information concerning options, water filters and -softeners.

units of measurement = mm

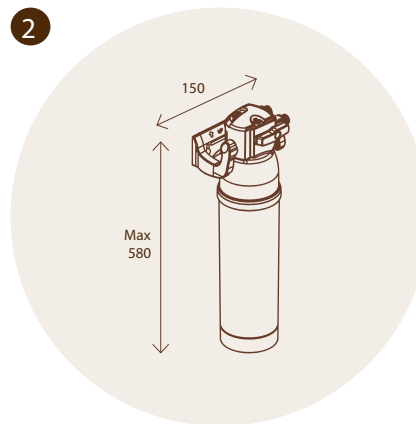
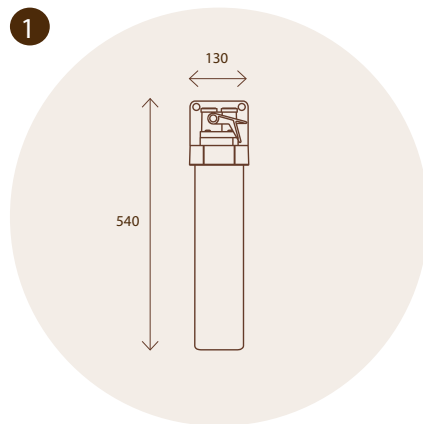

EXPLANATION

1. WATER FILTER

A filter may be necessary to optimize the water quality
The max required space is:
540 (h) x 130 (b) x 130 (d)

2. WATER SOFTENING (> 8 ° DH)

A water softener is necessary if the water hardness exceeds 8 ° DH.
The type required depends on the water hardness and daily number of consumptions.
The max required space is:
580 mm (l) x 150 mm (w) x 150 mm (d)

Please consult your local JDE Professional helpdesk for more information and explanation.
Please see the product brochure for more detailed information regarding range of available drinks, specifications, options and accessories.

Excellence Compact Black



Dimensions in detail

Additional detailed information concerning dimensions.

units of measurement = mm

Please consult your local JDE Professional helpdesk for more information and explanation.

Please see the product brochure for more detailed information regarding range of available drinks, specifications, options and accessories.

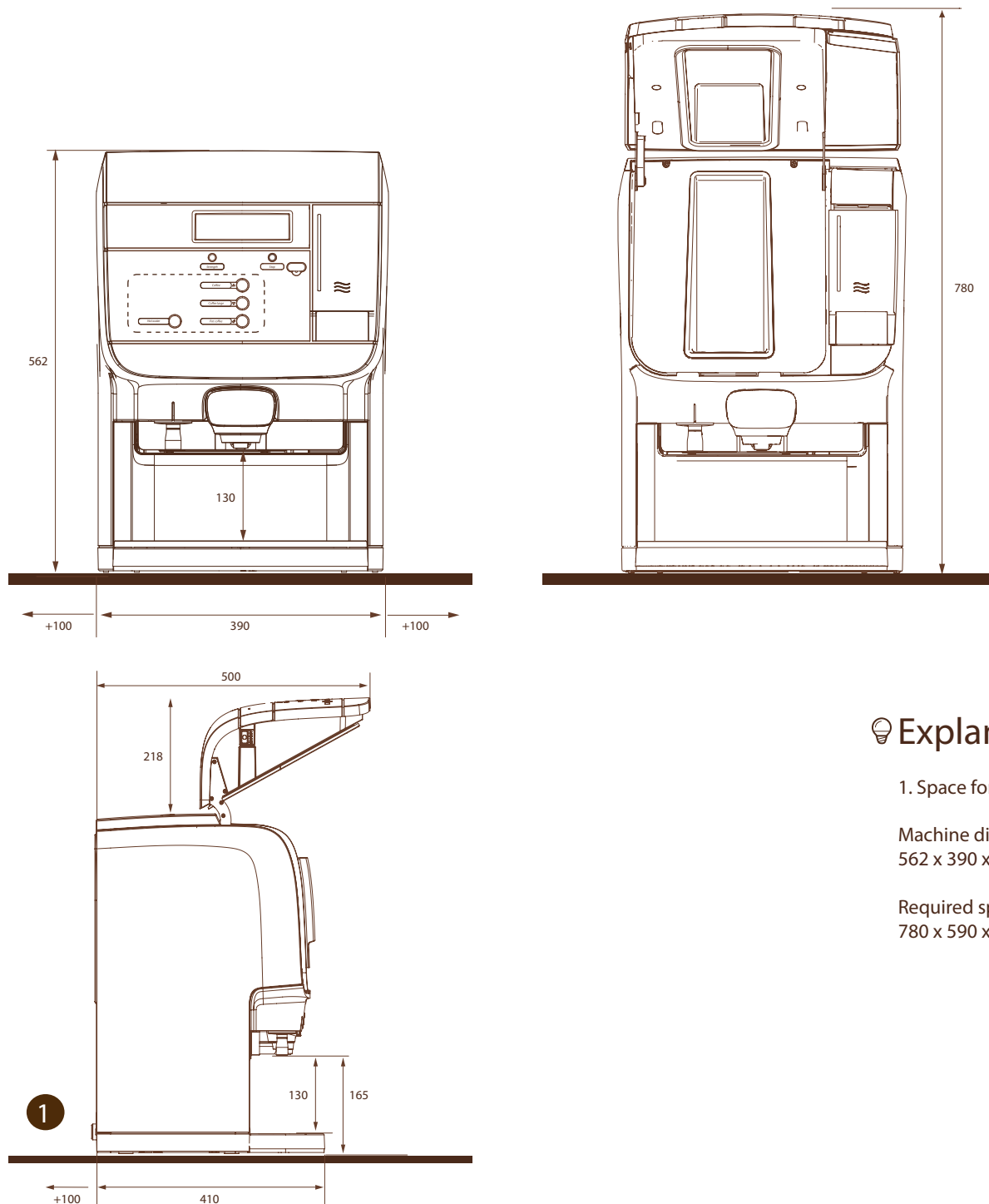

💡 Explanation

1. Space for ventilation

Machine dimensions (hxbxd):
562 x 390 x 410

Required space (hxbxd):
780 x 590 x 550